



# USER MANUAL



## ELEVATOR GEARLESS MACHINE INSTALLATION, OPERATION AND MAINTENANCE MANUAL

### GEARLESS MACHINE USER MANUAL

3.Organize Sanayi Bölgesi Kayacık Mahallesi  
T.Ziyaeddin Caddesi 6. Sokak No:2  
KONYA/TÜRKİYE  
Tel: 0 332 239 07 29 (pbx)  
Fax: 0 332 239 07 59  
www.akisasansor.com.tr



# CONTENTS

SHEET OF CONTENTS .....	2
LIST OF FIGURES.....	3
LIST OF TABLES.....	3
PURPOSE.....	4
COMPANY PROFILE.....	5
1. INTRODUCTION.....	6
2. COPYRIGHT.....	6
3. BASIC INFORMATION.....	6
4. GENERAL WARNINGS.....	6
5. SHIPPING.....	7
6. STORAGE.....	9
7. SAFETY INSTRUCTIONS.....	9
8. INSTALLATION.....	10
8.1. Assembly .....	10
8.2. Motor Electrical Connection .....	10
9. ENCODER MOUNTING.....	11
9.1. Encoder Installation.....	11
9.2. Encoder Removal Procedure.....	11
9.3. Gearless Elevator Machines Encoder Replacement Instruction.....	12
9.4. Encoder Connection Diagrams.....	14
10. BRAKE ADJUSTMENT PROCEDURE.....	15
10.1. Air Range Adjustment Tolerance.....	15
10.2. Air Range Check and Adjustment.....	15
10.3. Brake Air Range Check.....	15
10.4. Brake Air Gap Adjustment.....	15
10.5. Brake Movement Control.....	15
10.6. Brake Operation Periods.....	16
11. CHECKING and ADJUSTMENT OF MICRO CONNECTORS.....	16
12. GEARLESS PULLEY REMOVAL.....	17
13. SERVICE and MAINTENANCE.....	17
14. GEARLESS LABEL INFORMATION.....	18
14.1. Machine Labels.....	18
14.2. Brake Labels.....	19
15. General description of machines and parts.....	20
15.1. Gearless Machine Parts List.....	20
16. ERRORS and SOLUTIONS.....	21



## LIST OF FIGURES

FIGURE 1. TRANSPORT STATUS OF MACHINERY .....	7
FIGURE 2. ENCODER INSTALLATION PROCESS .....	11
FIGURE 3. ENCODER DISASSEMBLY PROCESS .....	11
FIGURE 4. ENCODER COVERS .....	13
FIGURE 5. BEARING DEFLECTION PULLEY .....	20

## LIST OF SHEETS

1. ENDAT/1313 ENCODER CONNECTION DIAGRAM .....	14
2. SHEET 2. ELECTROMAGNETIC BRAKES DATA TABLE .....	15
3. SHEET 3. SERVICE and MAINTENANCE RECOMMENDATIONS .....	17
4. GEARLESS MACHINE PARTS LIST.....	20
SHEET 5. POSSIBLE ERRORS THAT MAY OCCUR, CAUSES AND SOLUTIONS .....	21



# OBJECTIVE



This manual contains the necessary assembly, application and maintenance instructions for our machines and motors, safety warnings during installation and operation.

The machine and motor must not be assembled and operated without reading the manual completely.

All of the operations described in this user manual must be carried out by qualified personnel in the lift sector.

IT IS FORBIDDEN TO DISMANTLE THE PARTS OF THE LIFT MACHINE WITHOUT THE KNOWLEDGE AND PERMISSION OF THE MANUFACTURER COMPANY, OTHERWISE THE WARRANTY WILL LOSE ITS VALIDITY.

WITH REGARD TO CONDITIONS AND LIMITATIONS OF USE, COMPLY WITH THE VALUES IN THE FLOW MACHINE ENGINE PRODUCT CATALOGUES.

IN CASE OF PART REPLACEMENT, IT IS NECESSARY TO CONTACT THE MANUFACTURER AND PROVIDE THE FOLLOWING INFORMATION.

SERIAL NUMBER



## COMPANY PROFILE

AKIŞ, of which technological foundation dates back to 1978, started the production of lift machines and motors with an integrated system by combining its experience and knowledge with new investments over time.

By continuously investing in its technology, today, it has become one of the most important companies in our country and its sector.

It continues its production with an integrated system in its facilities established in Konya Organized Industrial Zone on a total area of 100.000 m<sup>2</sup> of which 35.000 m<sup>2</sup> is covered.

With its modern casting facility with automatic moulding, state-of-the-art machining department and quality control laboratory with rich content, it produces elevator machines and motors above international standards.

It attaches great importance to R&D studies with its R&D department and university co-operation. In this context, it continuously increases its product range. It completed the Gearless project carried out jointly with TUBITAK and started mass production.

It attaches utmost importance to quality and reliability at every stage of production. In its laboratory, it carries out separate examinations and analyses of each part used in elevator machine motor production.

It has many local and international quality certificates such as ISO 9001:2008, CE, GOST, TSEK.

With its monthly production capacity, AKIŞ is the largest manufacturer of our country and the region and meets a large part of our country's need for lift machine motors. With the export attack in recent years, it exports to 40 countries in 5 different continents.



## 1.INTRODUCTION

These operating instructions are for the AKIŞ permanent magnet excited synchronous gearless motor Volpi Mrl 1, 2, 3, 4, 5 series; Volpi Mrl 2-2, 2-3, 2-4, 2-5, 2-6, 2-7, 2-8 series; AK 1, 2, 2, 3, 4, 5, 6 series; AK 2-2, 2-3, 2-4, 2-5, 2-6, 2-7, 2-8 series, S100, S200, S300, S400 homelift series and MÜgen Mrl 1, Mrl 2, Mrl 3 series. The instructions contained therein must be strictly adhered to.

All individuals involved in the operation of our machine must read, understand and apply the information contained in this manual carefully. AKIŞ is not responsible and cannot be held liable for any damages that may occur in cases where these instructions are not followed.

## 2.COPYRIGHT

The copyright of this user manual belongs to AKIŞ. If this manual is quoted or copied in whole or in part without permission, legal sanctions will be imposed on the persons who do so.

## 3. ESSENTIAL INFORMATIONS

Our AKIŞ permanent magnet synchronous gearless machines consist of synchronous motor, drive pulley, encoder and magnetic brake device.

It provides 60%-85% more efficiency than our machines with asynchronous motor. Thus, in addition to the energy saving it provides, it provides great advantages to the user with the fact that it does not contain a gear system in its structure and as a result, it has a longer life. The fact that the system does not require the use of oil provides advantages in terms of environmental pollution, fire hazard and costs during use.

Thanks to its compact structure, it does not require a machine room and saves space. It can be easily integrated into all kinds of buildings. It prevents shaking thanks to its regular periodicity in speed change. Thanks to its superior control system, it shows unique stopping and starting sensitivity.

## 4.GENERAL WARNINGS

Our motors operate in places with temperatures between -20 and +40 at the power values printed on them. In case of exceeding these temperatures, the company should be contacted or external applications should be made to ensure the continuity of the ambient temperature at this level.

The humidity of the environment where the motor will operate should not exceed 90%.

The maximum speed generated by the motor speed and pulley diameter is given on the motor label.



## 5.TRANSPORTATION

Check the general appearance of the material during delivery. If the machine is damaged, please inform our company with the serial number of the product.

There is a wedge under the machine to ensure easy transport of the machine. Remove this wedge during assembly and assemble the machine.

It is the responsibility of the customer to use or not to use wedges in the assembly of our machine.

The shipment of our machine must be carried out safely. During the loading and unloading of the machine, it must be acted very carefully against the danger of impact, shaking and falling.

Our machine must be loaded and unloaded in series without lowering and overlapping.

Due to the level difference between the machine and the drive pulley, when lowering the machine, care must be taken against the danger of falling hard on the drive pulley. This may cause the shaft of the machine to bend and the bolts to break.

Our machines have one or two lifting rings determined according to the machine weight. When our machines are lifted, they should be lowered and transported with the help of a rope by connecting the lifting rings.

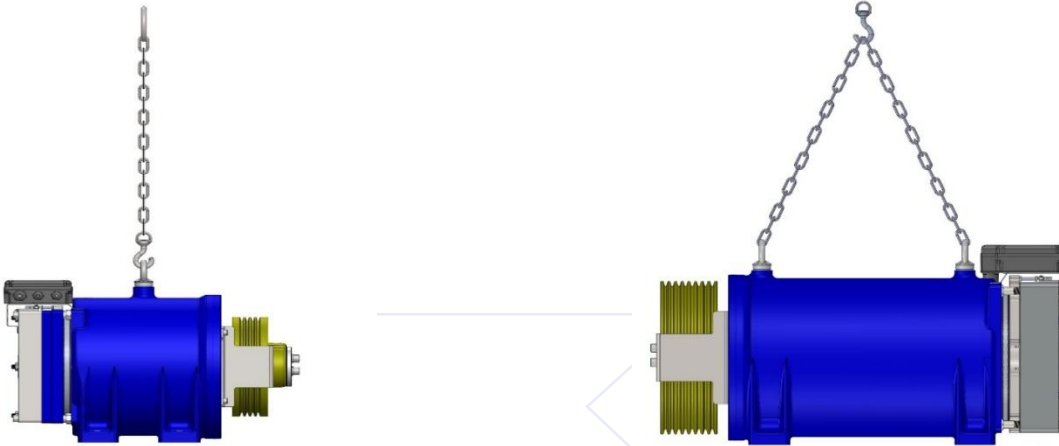

**Figure 1. Carriage Status of Machines**

In this section, the points to be used in lifting our machines manufactured by AKIŞ ASANSÖR and the techniques to be considered are shown.

It is the responsibility of the customer to check the suitability of the tools such as chains, steel ropes, belts, hooks, cranes and other lifting equipment to be used in the realisation of these operations.





**IT IS OF VITAL IMPORTANCE TO SHOW GREAT CARE AND ATTENTION AT EVERY STAGE OF HOOKING, LIFTING AND PLACING OUR MACHINE ON THE HOOK.**





## 6.STORAGE

-Our machine should be stored in its packaging in a damp and dry environment.

In case of long term storage, the machine must be protected against dust.

-Our machines should not be overlapped on top of each other and should be stored stably in a way not to take load from other materials.

-Contact with water should be prevented..

## 7.SECURITY INSTRUCTIONS



Since the motor will not produce a torque when the motor current is cut off, the lift will accelerate uncontrollably when the brakes are opened. Therefore, it is obligatory to short circuit the motor windings when the motor is de-energised.

From the installation of our machine to the trial test, all installation, connection and operation operations must be carried out by knowledgeable and authorised personnel. Every factor that may contribute to the machine not working properly should be taken into consideration and the most suitable area should be selected as the installation location. Environmental conditions should be taken into consideration; dusty, water-containing, excessively hot or cold places should be avoided if possible.

- -There must be an electrical earth system in the building where our machine will be installed.
- -The connection between our machine and the building grounding system must be provided with shielded power cables.
- -Micro contacts control the brake opening and closing. They must never be removed or deactivated.
- The connection of the U, V, W phase conductors on the cable to the terminal terminals must be connected according to the sequence of the successful result of the Auto-Tuning process.
- -Determine the capacity of our machine and motor correctly. Otherwise, our machine will be short-lived and cannot operate safely.
- -There is a PTC inside our permanent magnet excited synchronous motor against overheating. It should be supplied with max. 24 Volt DC voltage via the panel.
- Always take the lift out of operation when intervening in our machine and motor. Otherwise, injuries may be caused.
- -Installation of our machine and motor must be carried out by competent persons with sufficient training in accordance with the relevant standards and regulations.
- -The placement of our machine and motor must be done according to the relevant article of TS EN 81-1 standards.
- -There are 2 rope protection guards on our machine. These guardrails must never be removed.
- -If the sealed red points on the machine are interfered with, the machine is out of warranty.
- -Never weld on the machine. Because brake, magnets and bearings may be damaged. In such a case, the machine is out of warranty..



## 8.INSTALLATION

### 8.1. Assembly

The installation of our lift machine is carried out by placing it on steel construction or concrete floor. The seating of the machine is stable and vibration-free according to the EN 81-20-50 Standard used in lifts;

- The procedures and principles regarding the periodic control of elevators are determined by the Regulation on Elevator Operation, Maintenance and Periodic Control published in the Official Gazette dated 24/6/2015 and numbered 29396 and the Communiqué on Type A Inspection Institutions to be Authorized for Elevator Periodic Controls (SGM: 2015/24) published in the Official Gazette dated 15/7/2015 and numbered 29417 repeated 2.

- Referring to the article 1.16.12 published within the scope of the control criteria specified in Annex 1 "Periodic Control List for Electrically Driven Elevators" and Annex 2 "Periodic Control List for Hydraulically Driven Elevators" of the previous Communiqué; Noise and vibrations are not addressed in this standard, as they are not at levels that would be considered harmful for the safe use and maintenance of the lift. Imbalances in the assembly of the machine stand should be eliminated.

- There is no harm in not using bottom tyres in the assembly of these machines, whether or not to use bottom tyres belongs to the assembling company.

- In order for the surface on which our machine sits to be smooth, small protrusions such as burrs on the ground to be connected must be completely cleaned before installation.

- If our machine is to be mounted on concrete; if the concrete is safe, properly poured and frozen, tighten the fixing bolts completely.

- The base of our machine must be connected to the connection floor.

- The bolts and nuts used in the connection of our machine must be 4 pieces of 8\*8 quality M16 imbus bolts.

- After our machine is placed on the floor, the tightness of all bolts and nuts should be checked.

- In order to enable access to the encoder, at least 300 mm. distance should be left between the wall and the brake in the axial direction.

### •8.2. Motor Electrical Connection

- Connect the 3 phase connection cables coming out of the drive to the U,V,W contacts on the terminal block.

- Our electric motors are protected with IP 54 rating. It is protected against dust ingress enough to prevent normal operation of the product, but it is not dustproof. The product is fully protected against solid objects and splashes of water from any angle.

- protected.

- Connect the earth connection cable coming out of the inverter to the screw with earth label on the terminal block.

- Connect the cables coming out of the PTC, which is located inside the coil and makes temperature auto-control, to the ptc terminals in the terminal box.

- Connect the brake cables that provide the brake connection to the brake terminal on the terminal block.

- Connect the NO, COM and NC cables to match the contacts in the terminal box.

- It is important that you prefer cables with thermal protection relay and pass the PTC leads through the relay without bridging them for the long life of your motor.

- The cables used in the motor connection must comply with the standards.

- Cables used in motor connection must be well insulated.

- Cables must be fixed and taken to the panel.

- After the motor electrical connection is made, the terminal cover must be closed.

- Electric motor connection must be made in accordance with the relevant regulations and standards..

## 9. ENCODER ASSEMBLY

### 9.1. Encoder Installation

1. Remove the protective cover on the encoder.
2. Insert the encoder into the connection slot on the motor as shown in the figure.
3. Tighten the DIN6912-M5-8.8 bolt with ID 350 378-14 torque spanner with 5 - 5.5 Nm torque.
4. Tighten the fastening bolt on the encoder flange mounting ring with an AA 2 mm allen spanner with a torque of 1.2 Nm.

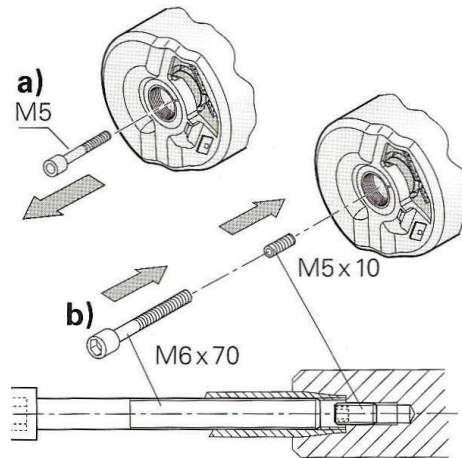

**Figure 2. Encoder installation process**

### 9.2. Encoder Disassembly

1. Remove the protective cover on the encoder.
2. Loosen the M5x60 screw in the center two turns.
3. Loosen the M2 screws on the flange clamping ring.
4. Thread the encoder by inserting the M10 bolt into the centre of the encoder and tighten until the encoder is removed.
5. Remove the encoder gently after loosening the encoder from the forehead.

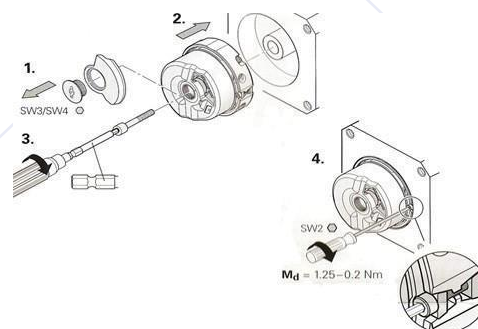

**Figure 3. Encoder disassembly process**



### 9.3. Gearless Elevator Machines Encoder Equipment Replacement Instruction

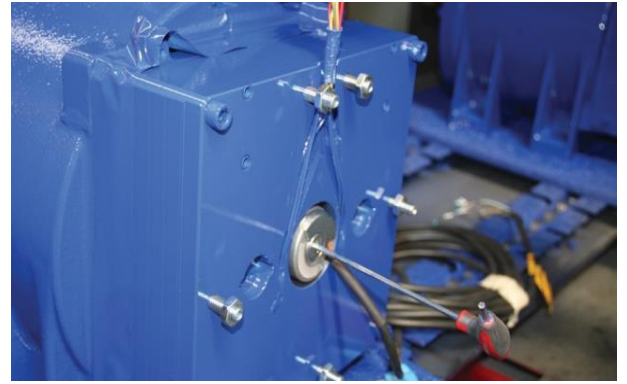

1. Disconnect the encoder from the panel. Remove the encoder cover with a suitable allen wrench. Remove it with a suitable allen wrench.



2. Remove the cable of the encoder from the terminal socket on the body.

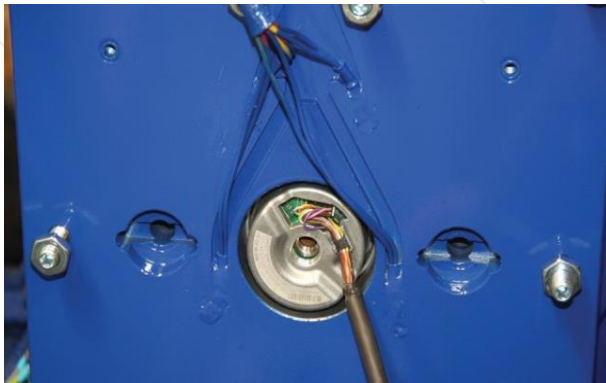

3. Remove the encoder with an allen wrench suitable for the hex-head bolt.



4. Loosen the hex-head bolt on the encoder housing retaining ring with a suitable allen wrench.

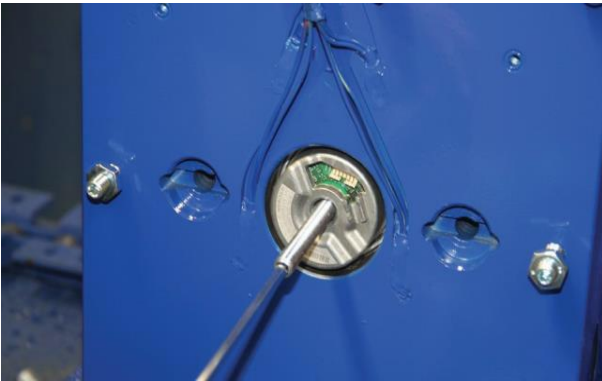

5. Remove the encoder from the machine body with the help of M10 bolt.



6. Replace the encoder on the machine body by reversing the procedure.

**Note:** After changing the encoder, you need to repeat the automatic setting process from the panel.



**Figure 4. Encoder Covers**



For more detailed information, please refer to the encoder manual or contact our company. Since the encoder is a sensitive electronic equipment, it should not be forced with excessive force during disassembly or assembly.



## 9.4. Encoder Connection Schemes

EnDat/1313 Encoder Bağlantı Şeması									
ECN 1313 Renk Kodu - ECN 1313 Color Code	GIE	DANFOSS	AR KEL	MEIDEN	OMRON YASKAVA	ABB	FUJİ	LG İV5	AYBEY ICA KARTI
		1							
		2							
Mavi (Yeşil Kahve)	+5V	3	UP (5V)	5 V	UP	11	PO	(+)	5V
Beyaz (Yeşil Beyaz)	GND (0V)	4	GND (0 V)	0 V	GND	12	CM	(-)	GND
Yeşil Siyah	A +	5	A +	PA	A +	6	PA +	A+	A
Sarı Siyah	A -	6	A -	RAN	A -	1	PA -	A-	A-
Mavi Siyah	B+	7	B +	PR	B +	7	PB +	B+	B
Kırmızı Siyah	B-	8	B -	PBN	B -	2	PB -	B-	B-
Mor	CLK +	9	CL +	PC	CL +	5	CK +	CLK+	CK
Sarı	CLK -	10	CL -	PCN	CL -	10	CK -	CLK-	CK-
Gri	D +	11	DA +	DP	DA +	14	DT +	DATA+	DT
Pembe	D -	12	DA -	DPN	DA -	15	DT -	DATA-	DT-

EnDat/1313 Encoder Connection Table									
ECN 1313 Renk Kodu - ECN 1313 Color Code	GIE	DANFOSS	AR KEL	MEIDEN	OMRON YASKAVA	ABB	FUJİ	LG İV5	AYBEY ICA CARD
		1							
		2							
Blue/(Brown W Green Stripe)	+5V	3	UP (5V)	5 V	UP	11	PO	(+)	5V
White/(White W Green Stripe)	GND (0V)	4	GND (0 V)	0 V	GND	12	CM	(-)	GND
Green W/ Black Stripe	A +	5	A +	PA	A +	6	PA +	A+	A
Yellow W/ Black Stripe	A -	6	A -	RAN	A -	1	PA -	A-	A-
Blue W/ Black Stripe	B+	7	B +	PR	B +	7	PB +	B+	B
Red W/ Black Stripe	B-	8	B -	PBN	B -	2	PB -	B-	B-
Purple	CLK +	9	CL +	PC	CL +	5	CK +	CLK+	CK
Yellow	CLK -	10	CL -	PCN	CL -	10	CK -	CLK-	CK-
Gray	D +	11	DA +	DP	DA +	14	DT +	DATA+	DT
Pink	D -	12	DA -	DPN	DA -	15	DT -	DATA-	DT-

Sheet 1. Endat /1313 Encoder Connection Diagram

## 10. BRAKE ADJUSTMENT PROCEDURE

### 10.1. Air Gap Adjustment Tolerance

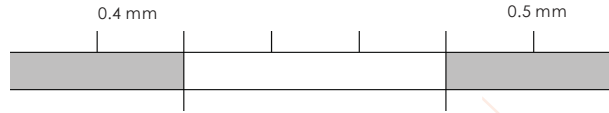

**Air Gap Adjustment Tolerances**

### 10.2. Air Range Control and Adjustment

BRAKE													
	AEMF1	AEMF2	AEMF3	AEMF4	AEMF5	AEMF6	AEMF7	AEMF8	AEMF9	AEMF10	AEMF11	AEMF12	AEMF13
Exciting/Holding Voltage[Vdc]	197/110	197/110	197/110	197/110	197/110	197/110	110/70	110/70	110/70	110/70	110/70	110/70	197/110
Nominal revolution [rpm]	534	534	298	298	298	534	534	534	298	298	298	534	240
Max. tripping revolution [rpm]	615	615	342	342	342	615	615	615	342	342	342	615	276
Ø Brake Lining [mm]	270	270	270	270	340	230	270	270	270	270	340	230	507
Max. Air Gap[mm]	0,45	0,45	0,40	0,40	0,50	0,40	0,45	0,45	0,40	0,40	0,50	0,40	0,50
Nominal Torque(Nm)	2*550=1100	2*650=1300	2*750=1500	2*875=1750	2*1100=2200	2*220=440	2*550=1100	2*650=1300	2*750=1500	2*900=1800	2*1100=2200	2*220=440	2*1300=2600
$T_{10}$ (ms)	40	40	40	20	40	25	40	40	40	30	40	25	50
$T_{50}$ (ms)	320	360	450	450	480	280	340	360	440	450	480	280	560

**Sheet 2. Data sheet for Electromagnetic Brakes**

### 10.3. Brake Air Range Inspection

Measure the air gap between the brake seat and the armature.

-If the air gap is between 0.40 mm and 0.50 mm, the brake works correctly.

### 10.4. Brake Air Gap Adjustment

Loosen the nut on the brake adjustment screw.

In order to prevent vibration of the spring, adjust the air gap between the centile and the brake box and brake chuck between 0.40-0.50 mm according to the brake type.

-Tighten the adjustment screws alternately so that you can slide the plates easily.

Lock the nuts again by holding the screws tightly.

-Finally, check the setting. If the result is successful, proceed to micro contact adjustment.

### 10.5. Brake Movement Control

Apply the brakes.

-Check the brake sound at every braking.

Check the freedom of the pulley rotation due to the brake oscillations.



## 10.6. Brake Working Periods

TYPES OF MACHINES	180/40 ST/H	240/60 ST/H
AK SERIES		✓
AKD SERIES		✓
VOLPI MRL SERIES		
MUGEN MRL SERIES	✓	
S SERIES	✓	

Stop-start (St/h)\* periods of our lift motors produced in our factory are shown in the table above.

- Flow series gearless (synchronous rotor and permanent magnet) machines are calculated according to 240/60 stop and take-off.
- Flow drum series gearless (synchronous rotor and permanent magnet) machines are calculated according to 240/60 stop and start temperature calculations.
- Volpi Mrl gearless (synchronous rotor and permanent magnet) machines are calculated according to 180/40 stop and start.
- Mügen Mrl gearless (synchronous rotor and permanent magnet) machines are calculated according to 180/40 stop and start.
- S series gearless (synchronous rotor and permanent magnet) machines are calculated according to 240/60 stop and start.

The table below shows the theoretical separation between working time and non-working time according to the planned starting hours.

ST / H	TOTAL CYCLE	WORK CYCLE	STOP CYCLE	GAP
240	15	9	6	60%
180	20	8	12	40%

\*St/h in the sentence;

**St:Operating frequency;h:Operating time capacity**

**For example; 240/60 value stated on the label shows that our machine will make 240 stops and starts in 1 hour. In this work, it will work 60% and stop 40%. It will work 144 times and stop 96 times.**

**(In 60 minutes, it will work for 36 minutes and stop for 24 minutes).**

## 11. CONTROL AND ADJUSTMENT OF MICRO CONTACTS

Each brake has a micro contact.

The micro contacts are closed when the brakes are active.

The micro contacts are wired in series.

Check the micro contacts using the buzzer setting of an ohmmeter.

Check each micro contact in sequence by shorting the others.

The check should be repeated several times with the brake activated, provided that the brake disc rotates a minimum of 3 turns at equal intervals.

The adjustment must be repeated several times with the brake activated.

Tighten the nut lightly using the M5 spanner group, adjust and tighten the screw. Then lock the nut by tightening it more than half a turn.



If there is a signal from the microcontact that the brake has been released, the drive will continue to run the motor. If there is a signal from the micro-contact that the brake has not been released, the drive will stop running. Thus, the motor will not draw a current much above its rated current to overcome the brake torque. This eliminates the risk of damage to both the drive and the motor due to excessive current.





## 12. GEARLESS SHEAVE DISASSEMBLY

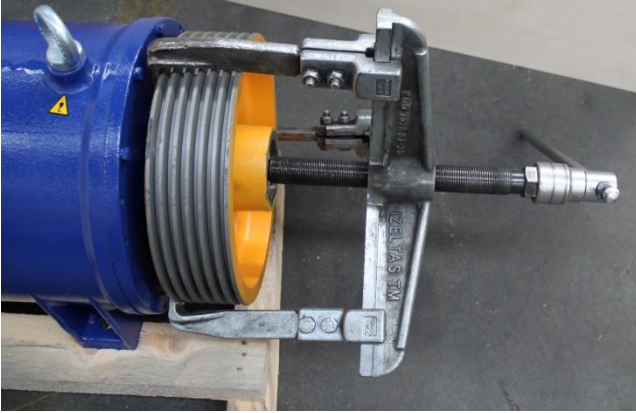

1. It is recommended to use a three-legged puller for sheave disassembly.

The process is carried out by grasping the sheave from three regions.

2. In order to assist the disassembly of the sheave, the disassembly process can be supported by hitting the foot points of the tripod puller with any hard material.

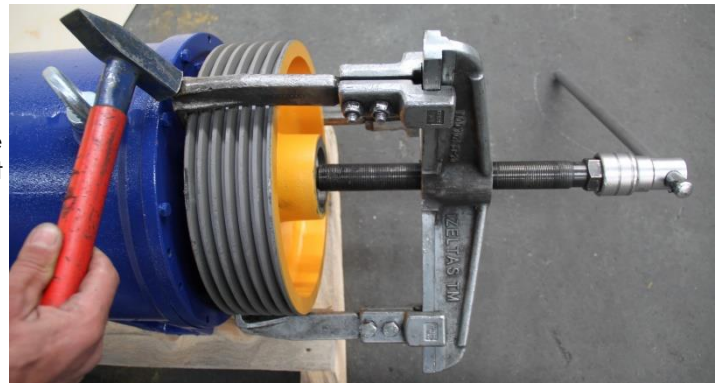

## 13. SERVICE AND MAINTENANCE

Service and maintenance must be provided by authorized and qualified personnel.

The bearings in the magnet-excited synchronous motor do not need external lubrication. Absolutely do not try to lubricate.



Control to be performed	Frequency of Control
Distance of the rope protection arm to the ropes (2-3 mm)	Once every 6 months
Uninterruptible Power Supply (UPS) operation control	During monthly inspections
General Control: Checking the tightness of the bolts, checking the operation of the drive pulley and brakes	During monthly inspections
Wear check of sheave	During annual inspections





**Sheet 3. Service and Maintenance Recommendations**







## 14. GEARLESS LABEL DETAILS

### 14.1. Machine Labels

AKIS		Kayacık Mah. Ziyaeddin Cad. 6.Sk No:2 Selçuklu-Konya-Türkiye Tel : +90 332 2390729 Fax : +90 332 2390759		  <small>(ISO 9001:2008)</small>  <small>MADE IN TÜRKİYE</small>	
Tip Type		www.akisasansor.com.tr	Frekans (Frequency)		Hz
Seri No Serial No			St/h		%Yük %ED
Hız Speed	m/s		Devir (n <sub>n</sub> ) Revolution(n <sub>n</sub> )		rpm
Gerilim Voltage	V		Moment (M <sub>n</sub> )		Nm
Güç (Pn) Power (Pn)	kW		İzo Sınıfı Iso Class		
Nominal Akım (I <sub>n</sub> ) Nominal Current (I <sub>n</sub> )	A		Bağlantı Şekli Connection Type		
Üretim Tarihi Production Date			Yük Load		kg
Kutup Sayısı Pole Number			Askı Suspension		
Enkoder Tipi Encoder Type			Ağırlık Weight		kg
Encoder Pulse			Koruma Sınıfı Protec. Class	IP 54	Made in Türkiye

volpi		Made in Türkiye 		 	
Tip Type		www.akisasansor.com.tr	Frekans (Frequency)		Hz
Seri No Serial No			St/h		%Yük %ED
Hız Speed	m/s		Devir (n <sub>n</sub> ) Revolution(n <sub>n</sub> )		rpm
Gerilim Voltage	V		Moment (M <sub>n</sub> )		Nm
Güç (Pn) Power (Pn)	kW		İzo Sınıfı Iso Class		
Nominal Akım (I <sub>n</sub> ) Nominal Current (I <sub>n</sub> )	A		Bağlantı Şekli Connection Type		
Üretim Tarihi Production Date			Yük Load		kg
Kutup Sayısı Pole Number			Askı Suspension		
Enkoder Tipi Encoder Type			Ağırlık Weight		kg
Encoder Pulse			Koruma Sınıfı Protec. Class	IP 54	Manufactured by 

mugen		Made in Türkiye 		 	
Tip Type		www.akisasansor.com.tr	Frekans (Frequency)		Hz
Seri No Serial No			St/h		%Yük %ED
Hız Speed	m/s		Devir (n <sub>n</sub> ) Revolution(n <sub>n</sub> )		rpm
Gerilim Voltage	V		Moment (M <sub>n</sub> )		Nm
Güç (Pn) Power (Pn)	kW		İzo Sınıfı Iso Class		
Nominal Akım (I <sub>n</sub> ) Nominal Current (I <sub>n</sub> )	A		Bağlantı Şekli Connection Type		
Üretim Tarihi Production Date			Yük Load		kg
Kutup Sayısı Pole Number			Askı Suspension		
Enkoder Tipi Encoder Type			Ağırlık Weight		kg
Encoder Pulse			Koruma Sınıfı Protec. Class	IP 54	Manufactured by 

**Type:** Specifies the type of machine.

**Serial number:** Machine production serial number

**Speed:** Machine nominal speed

**Voltage:** Machine rated voltage

**Power:** Machine rated power

**Nominal Current:** Machine rated current

**Date of production:** Indicates the date of machine production

**Number of poles:** Number of machine poles

**Encoder Type:** Endat - SinCos

**Encoder Pulse:** 2048

**Frequency:** Machine rated frequency

**St/h:** Machine stop-start period

**Revolution:** Machine nominal revolution

**Moment:** Machine rated torque

**Iso Class:** Machine insulation class

**Connection Type:** Motor connection

**Load:** Machine rated capacity

**Suspension:** Machine rope suspension type

**Weight :** Machine weight

**Protection Class:** Machine protection type

5: Against dust accumulation

4: Against water from all directions

## 14.2.Brake Labels



**Serial No:** Brake production serial number

**Certificate No:** Certificate number of the brake

**Type:** Specifies the brake type.

**Power of brake:** Rated power of brakes

**Voltage of brake:** Pull: Tension of the brake  
Retention :Holding voltage of the brake

**Torque of brake:** Rated torque of the brake



Our standard brake voltage **198 V DC**

Applying a voltage lower than the operating voltage to the brake coil terminals will cause the brake not to operate fully. In this case, the motor may draw too much current and the motor may overheat or the inverter may trip. Applying higher voltage than the operating voltage will cause the brake to heat up quickly.



## 15. GENERAL DESCRIPTION OF THE MACHINE AND PARTS

General introduction of our gearless type machines manufactured by Akış Elevator is explained in this section.

### 15.1. Gearless Machine Parts List

Our gearless type machines have a load lifting capacity between 320 -3500 Kg.

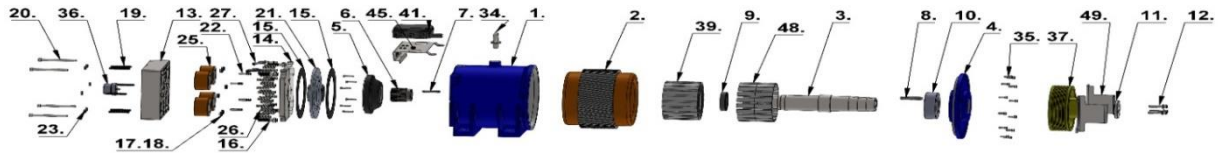

ITEM NUMBER	PART NUMBER	QTY	ITEM NUMBER	PART NUMBER	QTY
1	MACHINE BODY	1	26	BRAKE SPRING	32
2	STATOR PACK	1	27	IGNITION BOARD	2
3	ROTOR SHAFT	1	28	MICRO CONTACT	2
4	FRONT COVER(Ball Bearing)	1	29	M3 NUT	2
5	REAR COVER(Ball Bearing)	1	30	M3*12 YSB SCREW	2
6	BRAKE SLEEVE	1	31	M3 WASHER	2
7	12*8*60 WEDGE	1	32	MICRO CONTACT MECHANISM HANDLE	2
8	20*12*75 WEDGE	1	33	IGNITION SCREW AND NUT	2
9	6013-2RSR BEARING	1	34	M16 HOOK	1
10	6216-2RS BEARING	1	35	M8*20 A.A. BOLT	12
11	TRACTION PULLEY WASHER	1	36	ENCODER	1
12	M12*50 HEX-HEAD BOLT	3	37	TRACTION PULLEY	1
13	BRAKE TERMINAL BOX	1	38	M6*30 HEX-HEAD BOLT	6
14	BRAKE MIRROR	2	39	ROTOR PULLEY	1
15	BRAKE LINING	2	40		1
16	M16 BRAKE ADJUSTING STUD	4	41	TERMINAL BOX AND COVER	1
17	BRAKE GASKET	6	42	MOTOR CONNECTOR	1
18	BRAKE GASKET WASHER	6	43	PG13,5 SLEEVE	1
19	M10*70 SET SCREW BOLT	6	44	PG9 SLEEVE	2
20	M10*120 HEX-HEAD BOLT	4	45	BRAKE GUARD RAIL SHEET	1
21	BRAKE DISC	1	46	M12 ROUNDEL	1
22	BRAKE MIRROR CENTRING PIN	8	47	10*8*100 WEDGE	1
23	M10 BRAKE ADJUSTING SET SCREW NUT	6	48	GEARLESS MAGNET	40
24	M5*10 A.A. IGNITION BOLT	2	49	ROPE GUARD RAIL	2
25	BRAKE CORE	4			

### Sheet 4. Gearless Machine Parts List

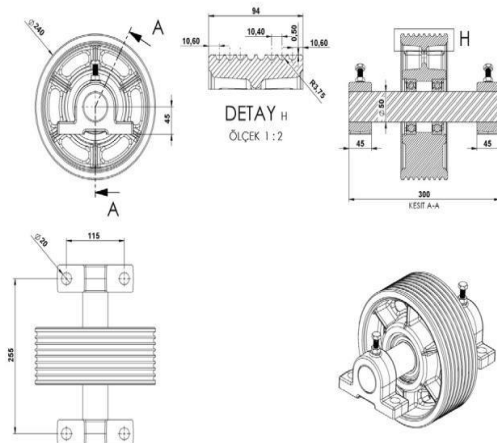

Figure 5. Bearing Deflection Pulley

## 16. ERRORS AND SOLUTIONS

POSSIBLE MALFUNCTIONS	POSSIBLE CAUSES	SOLUTION
Brake does not release	Brake voltage is low	The voltage on the label must be adjusted.
	Brake pad clearance settings have been tampered with.	Technical service personnel should be arranged by our company
	Brake coil burnt out.	It is repaired in our company.
Motor does not rotate	Failure to release the brake	. Refer to "Brake Does Not Release" in the table
	Voltage terminals are incorrectly connected	Voltage terminals must be connected according to the terminal block diagram.
	False signal from ignition	Contact connections must be made according to the diagram.
Leakage in the body	No earthing operation has been performed.	Earthing connection to the terminal cable must be fitted.
Motor draws excessive current	Voltage terminals connected incorrectly	Voltage terminals must be connected according to the terminal block diagram.
	The brake doesn't fully release.	Refer to "Brake Does Not Release" in the table.
	Inadequate counterweight balance.	Weight balance must be corrected.
After the machine stops on the floor , the cabin runs up and down	Driver settings are incorrect.	Brake closing delay time 1.5 sec. and contactor delay time 2.3 - 2.5 should be set in the range.
One channel of the pulley wear and tear	Incorrect adjustment of rope tightness	Adjusting the rope tightness settings to the same level.
Unsteady braking.	Low brake voltage	The voltage on the label must be adjusted.
	False signal from the ignition	Contact connections according to the scheme
The engine runs very noisy.	Incorrect driver settings	Driver settings should be checked
	Brake doesn't release	Refer to brake-related faults
The engine doesn't start.	Ignition may be out of adjustment	The ignition must be adjusted.
	Brake doesn't release	Refer to "Brake Does Not Release" in the table.
	Driver settings are incorrect.	Driver settings should be corrected.
	Incorrect terminal connections	Terminal connections must be made according to the diagram.

**The warranty is 2 years from the date of production.**

### Sheet 5. Possible errors, causes and solutions



**ENSURE THAT THE ELECTRICAL CONNECTION OF OUR ENGINE IS MADE BY PERSONNEL WITH SUFFICIENT TECHNICAL KNOWLEDGE.**

**ALWAYS DISCONNECT THE ELECTRICAL CONNECTION DURING REPAIR AND MAINTENANCE OPERATIONS.**



AT UYGUNLUK BEYANI  
EC- DECLARATION of CONFORMITY

İMALATÇI / MANUFACTURER :  
AKIŞ AŞANSÖR MAKİNA MOTOR DÖKÜM SAN. TİC. LTD. ŞTİ. AKIŞ İMALATÇI ADRESİ /  
MANUFACTURER ADDRESS:  
3. ORGANİZE SANAYİ BÖLGESİ KAYACIK MAHALLESİ. ZİYAEDDİN CAD.6. SK NO:2 KONYA /TÜRKİYE

ÜRÜN ADI / PRODUCT NAME :  
ELEKTRİKLİ SABİT MİKNATISLI SENKRON AŞANSÖR MOTORU / ELECTRICAL LIFT GEARLESS MOTOR

ÜRETİM YILI / YEAR OF MANUFACTURE:  
Etiket Üzerinde / See data plate on product

TİP /TYPE :  
AK1, AK2, AK3, AK4, AK5, AK6;AK2-2,AK2-3,AK2-4,AK2-5,AK2-6,AK2-7,AK2-8;  
Volpi Mrl 2-2, Volpi Mrl 2-3, Volpi Mrl 2-4, Volpi Mrl 2-5, Volpi Mrl 2-6, Volpi Mrl 2-7, Volpi Mrl 2-8  
Volpi Mrl 1,Volpi Mrl 2, Volpi Mrl 3,Volpi Mrl 4 ve Volpi Mrl 5  
Mügen Mrl 1,Mügen Mrl 2,Mügen Mrl 3  
S100,S200,S300,S400

SERİ NO/ SERIAL NUMBER :  
Etiket Üzerinde / See data plate on product

UYGULANAN DİREKTİFLER / THE FOLLOWING DIRECTIVES  
ELEKTRİKLİ TEÇHİZAT İLE İLGİLİ YÖNETMELİK 2006/95/AT -LVD DIRECTIVE 2006/95/EC

UYGULANAN STANDARTLAR / THE FOLLOWING STANDARTS  
TS EN 60034-1  
TS EN 81-1

ÜZERİNDE SERİ NUMARASI VE KAPASİTE BİLGİLERİ YER ALAN ÜRÜNÜN TESLİM EDİLEN  
KULLANIM VE BAKIM KILAVUZLARINDAKİ ŞARTLARA UYMASI DURUMUNDA YUKARIDA  
BELİRTİLEN STANDARTLARA VE DİREKTİFE UYGUNLUĞUNU BEYAN EDERİZ.

WE DECLARE THAT THE PRODUCT WITH SERIAL NUMBER AND CAPACITY INFORMATION ON IT  
COMPLIES WITH THE STANDARDS AND DIRECTIVE STATED ABOVE IF IT COMPLIES WITH THE  
CONDITIONS IN THE DELIVERED USE AND MAINTENANCE MANUALS.

YER-TARİH / PLACE-DATE  
: 16.01.2023 / KONYA  
YETKİLİ İMZA / LEGALLY BINDING SIGNATURE :

CE



This edition has been prepared in accordance with EN 81-1:1998+A3:2009 for elevator machines.

All rights of this catalogue belongs to AKIŞ ASANSÖR MAKİNE MOTOR DÖKÜM SANAYİ LTD. ŞTİ. All or part of the texts and numeration system may not be used in other editions, reprinted or translated without the written permission of AKIŞ ASANSÖR MAKİNE MOTOR DÖKÜM SANAYİ LTD. The company reserves the right to make changes it deems necessary at any time. It is the property of AKIŞ ASANSÖR MAKİNE MOTOR DÖKÜM SANAYİ LTD. ŞTİ.

